

Signal Booster Installation Guide



DataPro™
Direct Connect
800/1900 MHz
Smart Technology™
Signal Booster

Contents

Before Getting Started	1
Accessories and Antenna Options	1
Quick Installation Overview	2
Installation Diagram	2
Installing the External Adapter	3
Installing the Outside Antenna	3
Installing a Wilson Electronics Signal Booster	3
Powering Up a Wilson Electronics Signal Booster	3
Installing the Mounting Plate (sold separately)	4
Warnings and Recommendations	5
Guarantee and Warranty	6
Signal Booster SpecificationsBack Cover

Appearance of device and accessories may vary.

Note: This manual contains important safety and operating information. Please read and follow the instructions in this manual. Failure to do so could be hazardous and result in damage to your Signal Booster.

Installation Instructions for the Following Wilson Electronics Signal Booster:

DataPro: FCC ID: PWO2B1225 IC: 4726A-2B1225 Model: 2B1225

The term "IC" before the radio certification number only signifies that Industry Canada technical specifications were met.

Before Getting Started

This guide will help you properly install your Wilson Electronics Signal Booster. **It is important to read through all of the installation steps for your particular application prior to installing any equipment.** Read through the instructions, visualize where all the equipment will need to be installed and do a soft installation before mounting any equipment. For further assistance please call our Wilson Electronics Technical Support Team: 866-294-1660.

Inside this Package

Appearance of device and accessories may vary.



Accessories & Antenna Options (sold separately)

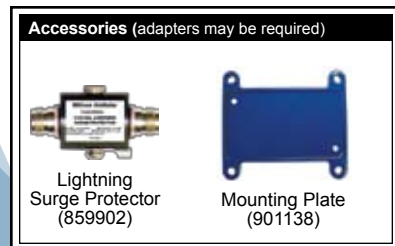
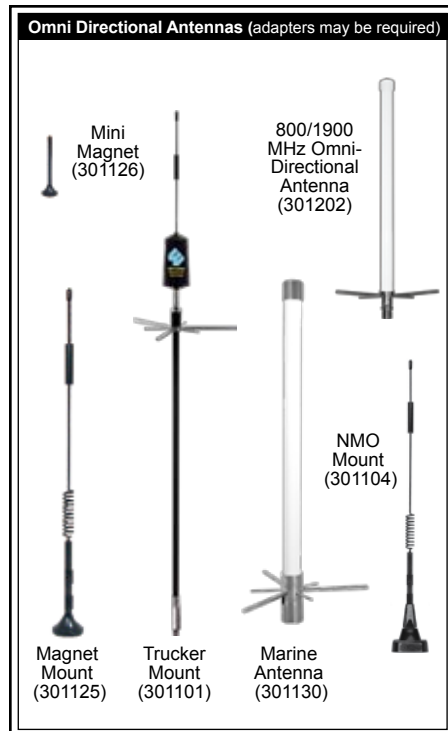
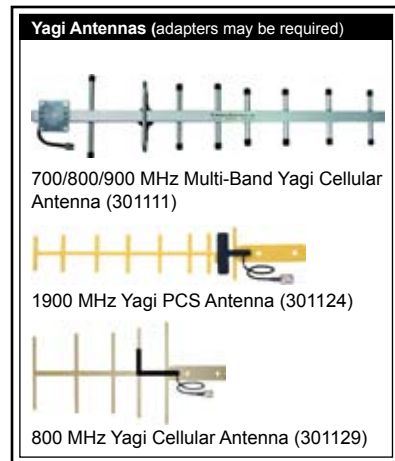

Quick Installation Overview

The following steps provide a summary of the Signal Booster/antenna installation process. Contact Wilson Electronics Technical Support Team with any questions at 866-294-1660.

1. Select a location to install the Signal Booster that is away from excessive heat, direct sunlight, moisture and that has proper ventilation. Do not place the Signal Booster in an air-tight enclosure.
2. Select a location on the top of the structure to install the Outside Antenna. Use a cell phone in test mode to find the strongest signal from the cell tower. Visit www.WilsonElectronics.com to find test mode function for your particular cell phone.
3. Run the Outside Antenna cable to the Signal Booster and attach it to the connector labeled "Outside Antenna."
4. An external adapter is required to connect the cell phone or cellular data card to the Signal Booster. The external adapter plugs into the included antenna extension cable and directly into a socket on the cellular device. Run the extension cable from the external adapter and attach it to the connector labeled "cellular phone or data card" on the Signal Booster.

Note: Be careful when plugging the connector in so as not to bend the center pins on the connectors. Ensure all cables have a tight connection.

5. Before powering up the Signal Booster verify that both the Outside Antenna and the Inside Antenna are connected and check that all connections are tight. An AC surge protector is recommended for all installations (not included).

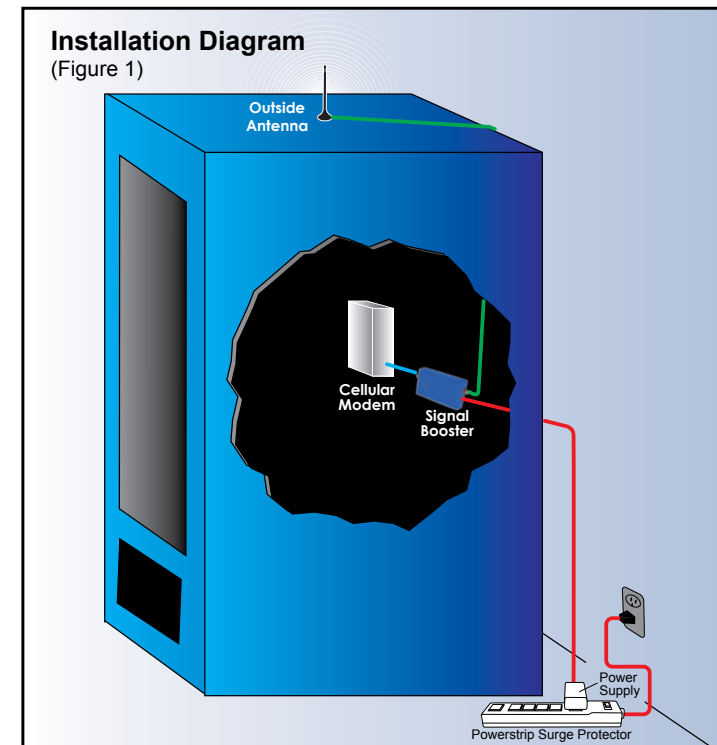

How it Works

Wilson Electronics Signal Boosters are bi-directional devices that deliver service levels consistent with what would be expected in areas of high cell network coverage. They amplify a weak or shadowed signal in mobile, marine, M2M and in-building applications. When using a Wilson Electronics Signal Booster in conjunction with Wilson Electronics antennas, the Outside Antenna will collect the cell tower signal and send it through the cable to the Signal Booster. Cell phones and cellular data cards then communicate with the improved signal. When a cellular device transmits, the signal is amplified by the Signal Booster and transmitted back to the cell tower through the Outside Antenna.

Installing the External Adapter

An external adapter is required to connect the cell phone or cellular data card to the Signal Booster. The external adapter is cell phone/data card-specific and may be purchased through a local retailer. Refer to Wilson Electronics Adapter Guide to identify the correct adapter for your cell phone or cellular data card. The adapter guide is available through a local retailer or at www.WilsonElectronics.com. The external adapter plugs into the antenna extension cable (included) and directly into a socket on the cellular device.

The external adapter and the extension cable are long enough to reach the Signal Booster location. This allows for ease and convenience of use. Run the extension cable from the external adapter and attach it to the connector labeled "Cellular Phone or Data Card" on the Signal Booster.

NOTE: Depending on your specific cell phone, the adapter socket may be located beneath a rubber plug.

Installing a Wilson Electronics Outside Antenna

Select a location on the top of the structure to install the Outside Antenna that has the most unobstructed line of sight to the cell tower. To obtain maximum performance, the antenna should point toward the cell tower. Follow the instructions included with the Outside Antenna and the RF Safety Warning (page 5). Run the cable from the Outside Antenna and attach it to the connector labeled "Outside Antenna" on the Signal Booster.

Lightning protection is recommended for all stationary installations (sold separately). Take extreme care to ensure neither you nor the antenna come in contact with any electrical power lines. Ensure there are at least three feet of clearance in all directions surrounding the antenna.

Installing a Wilson Electronics Signal Booster

Select a location to install the Signal Booster that is away from excessive heat, direct sunlight, moisture and that has proper ventilation. Ensure the Signal Booster is installed within six feet of where the cell phone or cellular data card will be used (to accommodate the six-foot adapter extension cable).

Powering up a Wilson Electronics Signal Booster

1. Ensure that both the Outside Antenna cable and the adapter cable are connected to the Signal Booster before powering up the Signal Booster.
2. Connect the power supply to the power input labeled with the USB symbol on the Signal Booster. Plug the power supply into a powerstrip surge protector (recommended).
3. The indicator light on the top of the Signal Booster will be GREEN when the unit is powered up and working properly.
4. If the light is off, ensure power supply connections are tight.



Warning: Verify that both the Outside Antenna and the adapter extension cable are connected to the Signal Booster before powering up the Signal Booster.



Warning: Use only a Wilson Electronics power supply. Use of a non-Wilson Electronics product could damage your equipment. It is recommended that all AC power supplies for home electronics be plugged into a **Surge Protector Power Strip**.

Carefully insert the power cable.



Testing a Wilson Electronics Signal Booster

To test your Signal Booster, go to a weak signal area where your cell phone registers only 1-2 bars without the Signal Booster turned on. Then, connect the Signal Booster to the phone and you should see a signal improvement of 2 or more bars. **Note:** Many phones take up to 30 seconds to reset the bar indicator.

Installing the Mounting Plate (sold separately)

To purchase a mounting plate call Wilson Electronics Sales Team 800-204-4104.

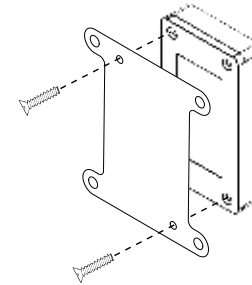

(PN# 901138)

Remove two screws from back of Signal Booster that correspond with the mounting plate.

Place Signal Booster on mounting plate and reinstall the two screws previously removed from back of Signal Booster.

Caution: Do not remove "Void Sticker."

Mobile Installation

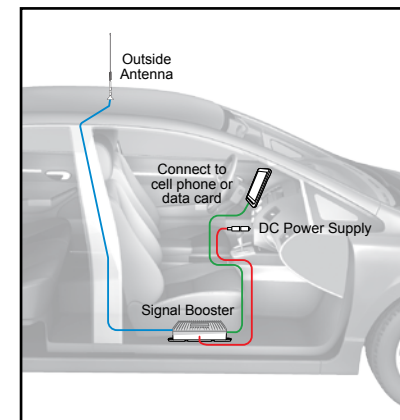

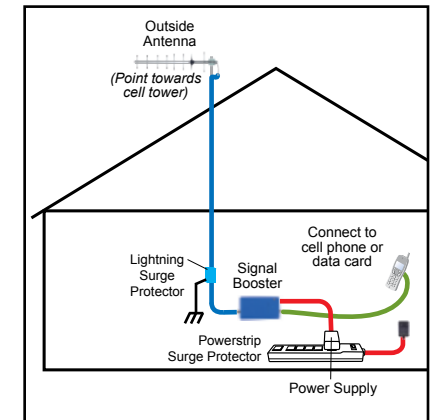

This is the recommended install for in-vehicle use. Contact our Technical Support Team for more information at: 866-294-1660 or tech@wilsonelectronics.com

In-Building Installation



This is the recommended install for in-building use. Contact our Technical Support Team for more information at: 866-294-1660 or tech@wilsonelectronics.com

Warnings and Recommendations

-  Warning: Verify that both the Outside Antenna and the adapter extension cable are connected to the Signal Booster before powering up the Signal Booster.
-  Warning: Use only the power supply provided in this package. Use of a non-Wilson Electronics products may damage your equipment.
-  Warning: **RF Safety:** All omni-directional antennas shown on page 1 must be installed so that the distance from the antenna to any person is no less than 8 inches. All Yagi antennas shown on page 1 must be installed so that the distance from the antenna to any person is no less than 26 inches. Yagi antennas may not be used indoors or in a mobile installation. Please contact Wilson Electronics Technical Support Team for safe distances from other antennas.

Lightning protection is recommended for all in-building installations.

It is recommended to verify that outside building antenna installations comply with relevant electrical codes (e.g. National Electrical Code).

NOTE: The aluminum casing of a Wilson Electronics Signal Booster will adjust very quickly to the ambient temperature of its environment. For example, in the summer, when the inside of a car can reach 140 degrees Fahrenheit, the Signal Booster temperature may be 150 degrees or higher. The casing will be hot to the touch, similar to a metal door handle or a steering wheel. Such high temperatures will not damage the Signal Booster, nor do they pose a fire risk to the structure. As recommended in these instructions, install the Signal Booster in a location with adequate ventilation. Keep the area free of items that could block air flow to the Signal Booster. Do not install the Signal Booster in direct sunlight.



About Wilson Electronics

Wilson Electronics, Inc. has been a leader in the wireless communications industry for over 40 years. The company designs and manufactures Signal Boosters, antennas and related components that significantly improve cellular telephone signal reception and transmission in a wide variety of applications, mobile, in-building, and M2M.

With extensive experience in antenna and Signal Booster research and design, the company's engineering team uses a state-of-the-art testing laboratory, including an anechoic chamber and network analyzers, to fine-tune antenna designs and performance. For its Signal Boosters, Wilson Electronics uses a double electrically insulated RF enclosure and cell tower simulators for compliance testing.

Wilson Electronics Signal Boosters feature patented Smart Technology™ that enables them to automatically adjust their power based on cell tower requirements. By detecting and preventing oscillation feedback, signal overload and interference with other users, these Smart Technology™ Signal Boosters improve network cell phone areas without compromising carrier systems.

All products are engineered and assembled in the company's 55,000-square-foot headquarters in St. George, Utah. Wilson Electronics has product dealers in all 50 states as well as in countries around the world.

30-Day Money-Back Guarantee

All Wilson Electronics products are protected by Wilson Electronic's 30-day money-back guarantee. If for any reason the performance of any product is not acceptable, simply return the product directly to the reseller with a dated proof of purchase.

1-Year Warranty

Wilson Electronics Signal Boosters are warranted for one (1) year against defects in workmanship and/or materials. Warranty cases may be resolved by returning the product directly to the reseller with a dated proof of purchase.

Signal Boosters may also be returned directly to the manufacturer at the consumer's expense, with a dated proof of purchase and a Returned Material Authorization (RMA) number supplied by Wilson Electronics. Wilson Electronics shall, at its option, either repair or replace the product. Wilson Electronics will pay for delivery of the repaired or replaced product back to the original consumer if located within the continental U.S.

This warranty does not apply to any Signal Boosters determined by Wilson Electronics to have been subjected to misuse, abuse, neglect, or mishandling that alters or damages physical or electronic properties.

RMA numbers may be obtained by phoning Technical Support at 866-294-1660.

Disclaimer: The information provided by Wilson Electronics, Inc. is believed to be complete and accurate. However, no responsibility is assumed by Wilson Electronics, Inc. for any business or personal losses arising from its use, or for any infringements of patents or other rights of third parties that may result from its use.

Copyright © 2011 Wilson Electronics, Inc. All rights reserved.

This device complies with part 15 of the FCC Rules. Operation is subject to the following two conditions: (1) This device may not cause harmful interference, and (2) this device must accept any interference received, including interference that may cause undesired operation. Changes or modifications made that are not expressly approved by Wilson Electronics could void authority to operate this equipment.

One or more of the following U.S. Patent numbers may apply to the Signal Booster in this product – D596,614; D596,615; D563,381; 7,729,669; 7,486,929; 7,729,656; 7,409,186; 7,783,318; 7,684,838; 12,714,994.

Signal Booster Specifications

		Dual-Band 800/1900 MHz Specifications	
Model Number / Part Number		2B1225	
Connectors		SMA Female	
Impedance (input/output)		50 ohms	
Dimensions			
with mounting plate		3.9 x 3.1 x 0.95 in	
without mounting plate		3.9 x 1.9 x .085 in	
Frequency		824-894 MHz / 1850-1990 MHz	
¹Passband Gain (nominal)		Factory set: 5 dB minimum to 15 dB maximum	
²20 dB Bandwidth (nominal)			
700 MHz			
800 MHz		30 MHz	
1900 MHz		68 MHz	
³Power output for single cell phone (uplink)		800 MHz	1900 MHz
CDMA		30.0 dBm	32.7 dBm
GSM		29.4 dBm	29.0 dBm
EDGE		28.3 dBm	28.9 dBm
WCDMA		31.5 dBm	32.4 dBm
LTE			
³Power output for single received channel (downlink)		800 MHz	1900 MHz
CDMA		-3.2 dBm	1.5 dBm
GSM		-2.4 dBm	-1.5 dBm
EDGE		-3.3 dBm	-1.5 dBm
WCDMA		-3.8 dBm	-2.0 dBm
LTE			
⁴Power output for multiple received channels (downlink). The maximum power is reduced by the number of channels:		Maximum Power ³	
Number of channels:		800 MHz	1900 MHz
2		-10.9 dBm	-5.2 dBm
3		-14.4 dBm	-8.8 dBm
4		-16.9 dBm	-11.3 dBm
5		-18.9 dBm	-13.2 dBm
6		-20.5 dBm	-14.8 dBm
Noise Figure (typical)		3 dB nominal	
Isolation		> 60 dB	
Power Requirements		5V DC, 1A	

Notes:

- Nominal gain is the maximum gain at any frequency in the passband.
- Nominal bandwidth is the difference between two frequencies that are adjacent to the passband where the amplification is 20 dB lower than the passband amplification. One of the frequencies is lower than the passband and the other is higher.
- The Manufacturer's rated output power of this equipment is for single carrier operation. For situations when multiple carrier signals are present, the rating would have to be reduced by 3.5 dB, especially where the output signal is re-radiated and can cause interference to adjacent band users. This power reduction is to be by means of input power or gain reduction and not by an attenuator at the output of the device.
- The maximum power for 2 or more simultaneous signals will be reduced by 6 dB every time the number of signals is doubled.



3301 East Deseret Drive, St. George, UT 84790

For additional Technical Support visit www.WilsonElectronics.com

or email at: tech@wilsonelectronics.com

Phone: 866-294-1660 Local: 435-673-5021 Fax: 435-656-2432

www.twitter.com/WilsonCellular www.facebook.com/WilsonCellular